

FAHRENHEIT 451

COMPREHENSION GUIDE

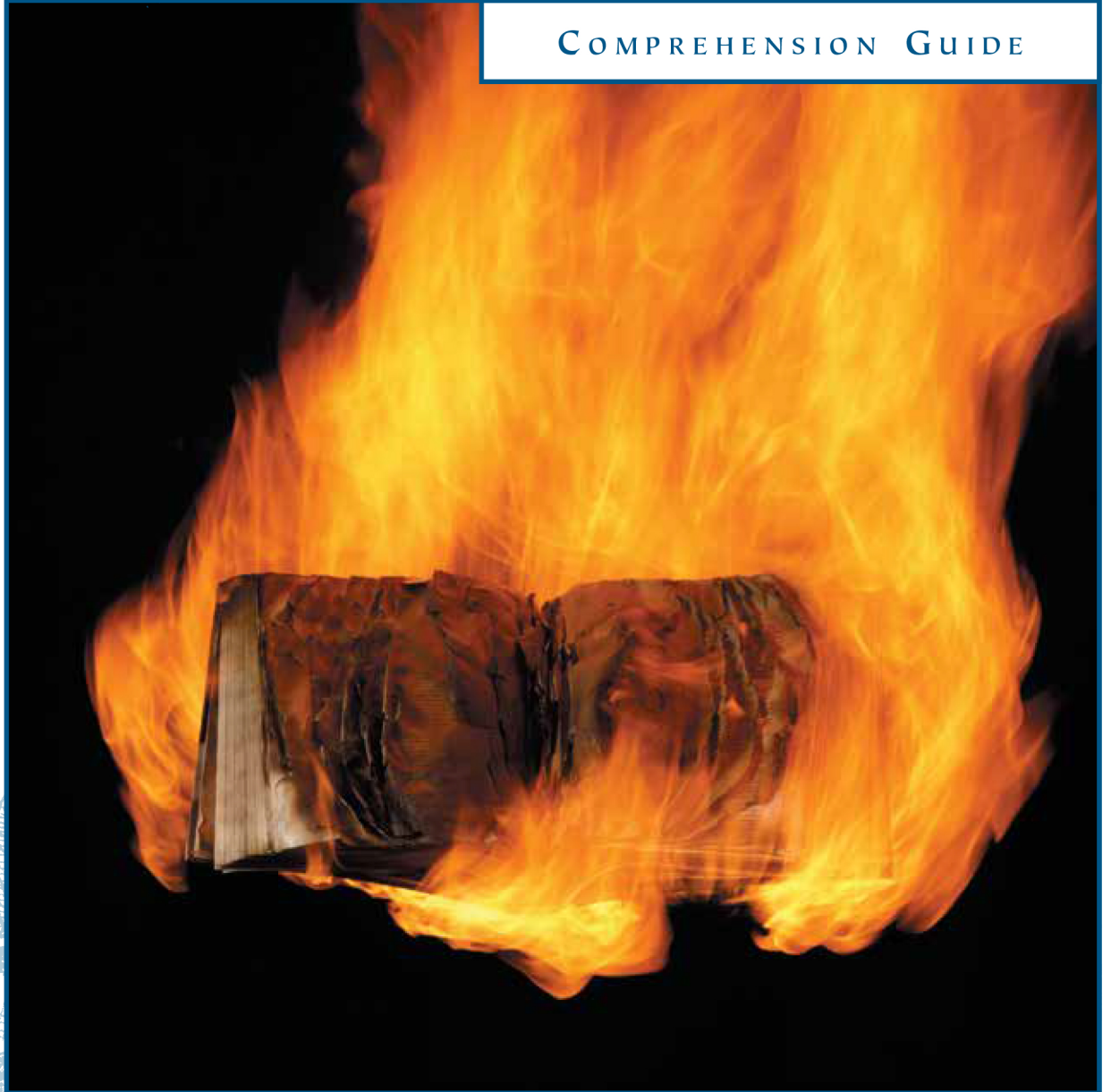

VEXCLUSTRE
P

FAHRENHEIT 451

Comprehension Guide
by Ned Bustard

Illustrations by
Matthew Clark



veritas
PRESS

Copyright ©2004 Veritas Press, Inc.
www.VeritasPress.com
ISBN 978-1-932168-19-8

All rights reserved. Permission is granted to make unlimited photocopies of this entire manual for the school or homeschool that purchased this manual. Otherwise, no part of this book may be reproduced without permission from Veritas Press, except by a reviewer who may quote brief passages in a review; nor may any part of this book be reproduced, stored in a retrieval system or transmitted in any form by any means, electronic, mechanical, photocopying, recording or otherwise, without prior permission from Veritas Press.

Printed in the United States of America.

FAHRENHEIT 451

How to Use this Guide

This guide is intended to help you study, understand, and enjoy *Fahrenheit 451*—a book over half a century old that itself is the phoenix reborn from the ashes of an earlier work entitled *The Fire Man* which told the story of a municipal department in the year 1999 that came to your house to start fires instead of to put them out.

You might ask if a guide is really necessary to read a book. Is the student not just working to improve reading skills while being taught to enjoy reading a book? Certainly, it is the case that the more a child reads, the more he should improve his skills, but quantity is not the only issue. Once a child has received adequate phonetic training, he should learn how to read a book. Most educators using this guide will be teaching children in the upper grammar stage, generally understood to be during the later elementary years in a classical education. (For a thorough understanding of classical Christian education we recommend reading *Recovering the Lost Tools of Learning* or *The Case for Classical Christian Education*, both by Douglas Wilson.) The basic goals of reading in the grammar stage are as follows:

The student should be able to:

1. Fluently read a given selection orally.
2. Show an increased desire for reading.
3. Show comprehension on a literal and inferential level.
4. Demonstrate an increased vocabulary.
5. Identify basic Biblical values in the literature being read.
6. Identify various styles (myths, poems, fantasy, fiction, nonfiction, etc.)

This book is an excellent tool to transition children into the dialectic stage. There are questions and projects that will cause students to look at the big picture and connect their worldview, rather than just answering comprehension questions.

Answers to the questions are found in the back of the guide. Although the answers in the guide appear in abbreviated form, the students' answers should be in complete sentences, and they should restate the question in their answer.

Example:

Question: How old does Clarisse claim to be?

Answer: Clarisse claims to be seventeen.

Such writing practice trains the student to answer thoroughly, completely, and with proper grammar. Another reason is to encourage integration. We want students to understand that how they write something is as important as what they write.

You may wonder how to grade the student's work in this guide. Keep it simple. Unless otherwise indicated you should assume that each question is worth five points.

Using this guide to teach *Fahrenheit 451* can be done in two ways. There is a project breaking up the questions into ten sections for a two week study, or you can devote five days to each of the three sections of the book and stretch the unit to run over fifteen days. Use the guide as best suits your students, adding or deleting projects and questions as needed.

FAHRENHEIT 451

The Hearth and the Salamander

1. Describe the uniform of the fireman.

2. How did Montag go down the pole, and what might this say about his personality?

3. How did Clarisse's appearance contrast with the appearance of Montag?

4. How old did Clarisse claim to be?

5. What strange assertion did Clarisse make about those who were part of Montag's career in the past?

FAHRENHEIT 451

The Hearth and the Salamander

6. Why did Montag's laughter puzzle Clarisse?

7. For what was Clarisse's uncle jailed two days?

8. What last question did Clarisse set that stopped his laughing?

9. As Montag stood beneath the vent grille, what event did he associate with the strange meeting he had just had with the girl?



FAHRENHEIT 451

The Hearth and the Salamander

10. “The bedroom was indeed empty.” How was this a true and a false thought for Montag to mull on?

11. What screamed in the sky for Montag when he found the empty bottle under the edge of his bed?

12. What did the machines that were brought by the emergency hospital operators do to Mildred?

13. Why were the technicians that were sent not medical doctors?

14. List what constituted the “storm” that fell on Montag before he took a sleep lozenge?

FAHRENHEIT 451

The Hearth and the Salamander—Patch Project

In the space below, design a patch for the uniform of a fireman as they are described in this section of the book. Adventurous students could design different patches to indicate the various ranks of firemen.

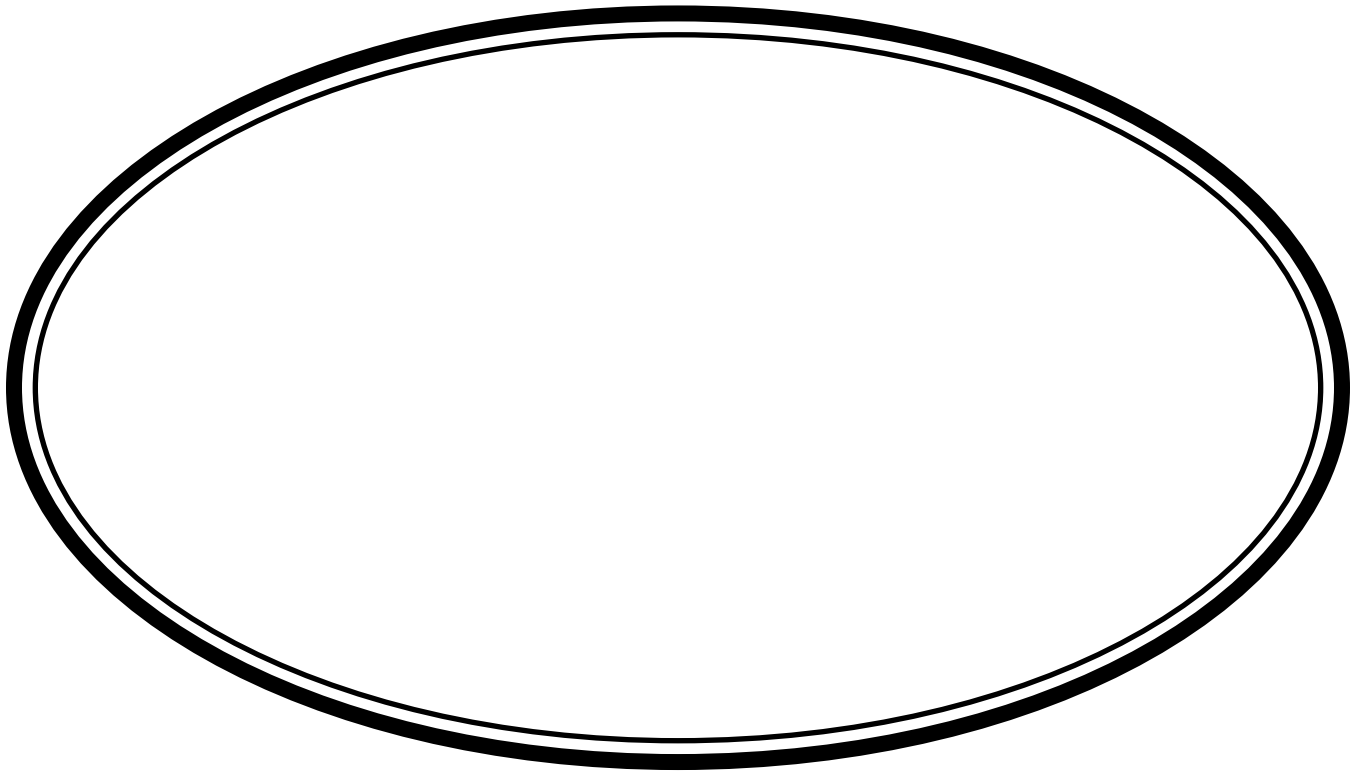
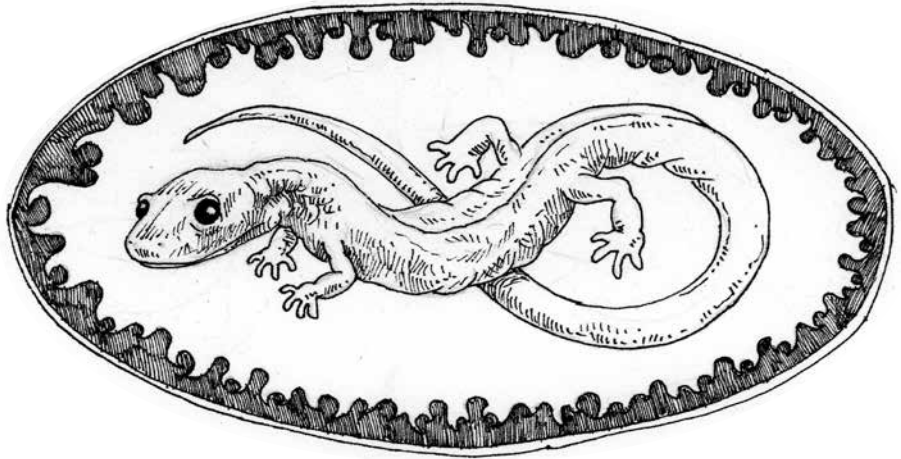

FAHRENHEIT 451

The Hearth and the Salamander

15. How had Mildred become an expert at reading lips?

16. What was Mildred's response to the suggestion that she had overdone the night before?

17. What did Mildred nag Montag to buy for their house?

18. What was Clarisse doing in the rain when Montag met up with her?

19. What did the dandelion show to Clarisse?

20. What did Clarisse find peculiar about Montag?

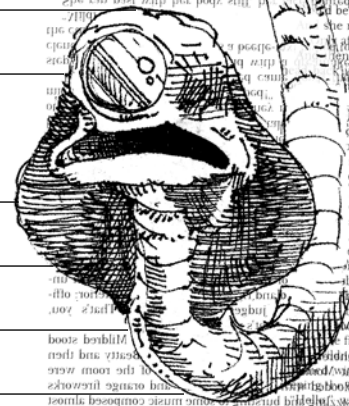

FAHRENHEIT 451

The Hearth and the Salamander

21. Describe the Mechanical Hound.

22. What was the response that the beast had to Montag?

23. Why did Montag think someone at the station might have programmed the Hound to threaten him?

24. What occurred every day of the following week?

25. What change did Clarisse observe in Montag when they resumed the conversation about billboards?

FAHRENHEIT 451

The Hearth and the Salamander—Project 2, Sci-Fi or Fact?

This book was first published in 1953, well before the age of music television and flat screen wall television units. List the things imagined by Ray Bradbury in the pages of this science fiction story and the equivalent real thing Bradbury correctly predicted in our culture today. You may want to revisit this project periodically as you read the entire book.

Sci-Fi Description

Contemporary Reality

_____	_____
_____	_____
_____	_____
_____	_____
_____	_____
_____	_____
_____	_____
_____	_____
_____	_____
_____	_____
_____	_____
_____	_____
_____	_____
_____	_____
_____	_____
_____	_____
_____	_____
_____	_____
_____	_____
_____	_____
_____	_____
_____	_____
_____	_____
_____	_____

FAHRENHEIT 451

The Hearth and the Salamander, Project 3—Book Binding

In the Afterword, Bradbury shares how he wrote new scenes for the book to be performed as a two-act drama. In that version of Fahrenheit 451 we learn how Beatty became the Fire Chief. When he takes Montag home to his apartment, it turns out to have thousands upon thousands of books lining the walls in a hidden library. Montag turns and cries out to his superior:

“But you’re the Chief Burner! You can’t have books on your premises!”

To which the Chief, with a dry light smile, replies: “It’s not owning books that’s a crime, Montag, it’s reading them! Yes, that’s right. I own books, but don’t read them!”

Montag, in shock, awaits Beatty’s explanation.

“Don’t you see the beauty, Montag? I never read them. Not one book, not one chapter, not one page, not one paragraph. I do play with ironies, don’t I? To have thousands of books and never crack one, to turn your back on the lot. . .”

Beatty insists that his collection of books is “no better than dust,” then recounts his own history when, as a boy, he was consumed with them until the tragedies of life happened to him. Then, when he looked to books for answers, he opened the pages of his library books and found the pages were empty.

“Oh, the words were there, alright, but they ran over my eyes like hot oil, signifying nothing. Offering no help, no solace, no peace, no harbor, no true love, no bed, no light.”

In this project, you will make a “book” that is actually blank.

Materials

- copier paper
- thicker art paper
- ribbon, yarn, or twine
- push pin

Directions

1. Cut the art paper to 9” x 14”. Holding the sheet lengthwise, fold in half and fold in 1-1/4” from either side. Open the paper and make three holes along the spine at 1-1/4,” 4-1/2,” and 7-3/4.”

2. Fold four sheets of copier paper in half and insert one into the other until you

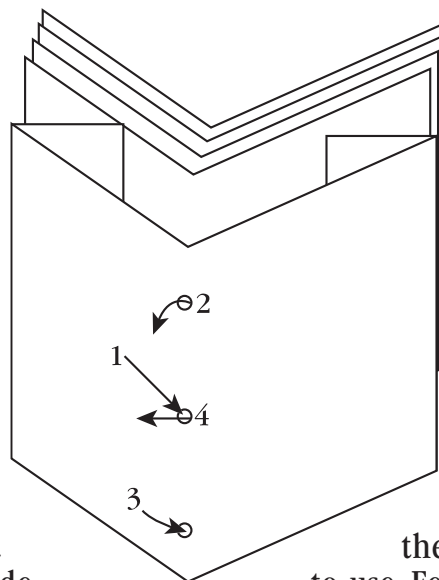

have a little booklet. Open and make three holes entirely through all four sheets along the spine at 1,” 4-1/4,” and 7-1/2.”

3. Put the set of folded and pierced copier sheets inside the cover and insure that the holes line up. Work the tip of a pencil or pen in the holes to make them large enough for the ribbon, yarn, or twine you plan to use. Feed the ribbon, yarn, or twine from the outside of the book through the center hole, up and back out the top hole, down the outside and into the bottom hole, finally back through the center hole again and tie the two ends off in a bow or square knot.

FAHRENHEIT 451

The Hearth and the Salamander

29. What did Montag realize as he reflected on the appearance of the other firemen as they played cards together?

30. What incriminating phrase did Montag use to begin his inquiry into the history of firemen?

31. Who was the first fireman in America?

32. What was the first thing the old woman at 11 No. Elm, City, said to the fireman before Captain Beatty slapped her?

33. How had the police “slipped,” spoiling the firemen’s ritual?

34. What did Montag’s hand do while magazines “fell like slaughtered birds?”

FAHRENHEIT 451

The Hearth and the Salamander

35. Besides the law, what common sense “truth” did Beatty appeal to while trying to get the old lady to come out of the house?

36. What did the old lady possess that made the firemen drop all their dignity and run out of the house?

37. What did Captain Beatty do that so startled Montag and Stoneman that they missed their turn to return to the firehouse?

38. Unlike his wife swallowing “poison” in the form of an overdose of sleeping pills, how and where was Montag infected by a “poison?”

39. Regarding their relationship, what question that Mildred was unable to answer troubled Montag?

FAHRENHEIT 451

The Hearth and the Salamander

40. What did Montag finally decide had come between him and his wife?

41. What happened to Clarisse four days earlier?

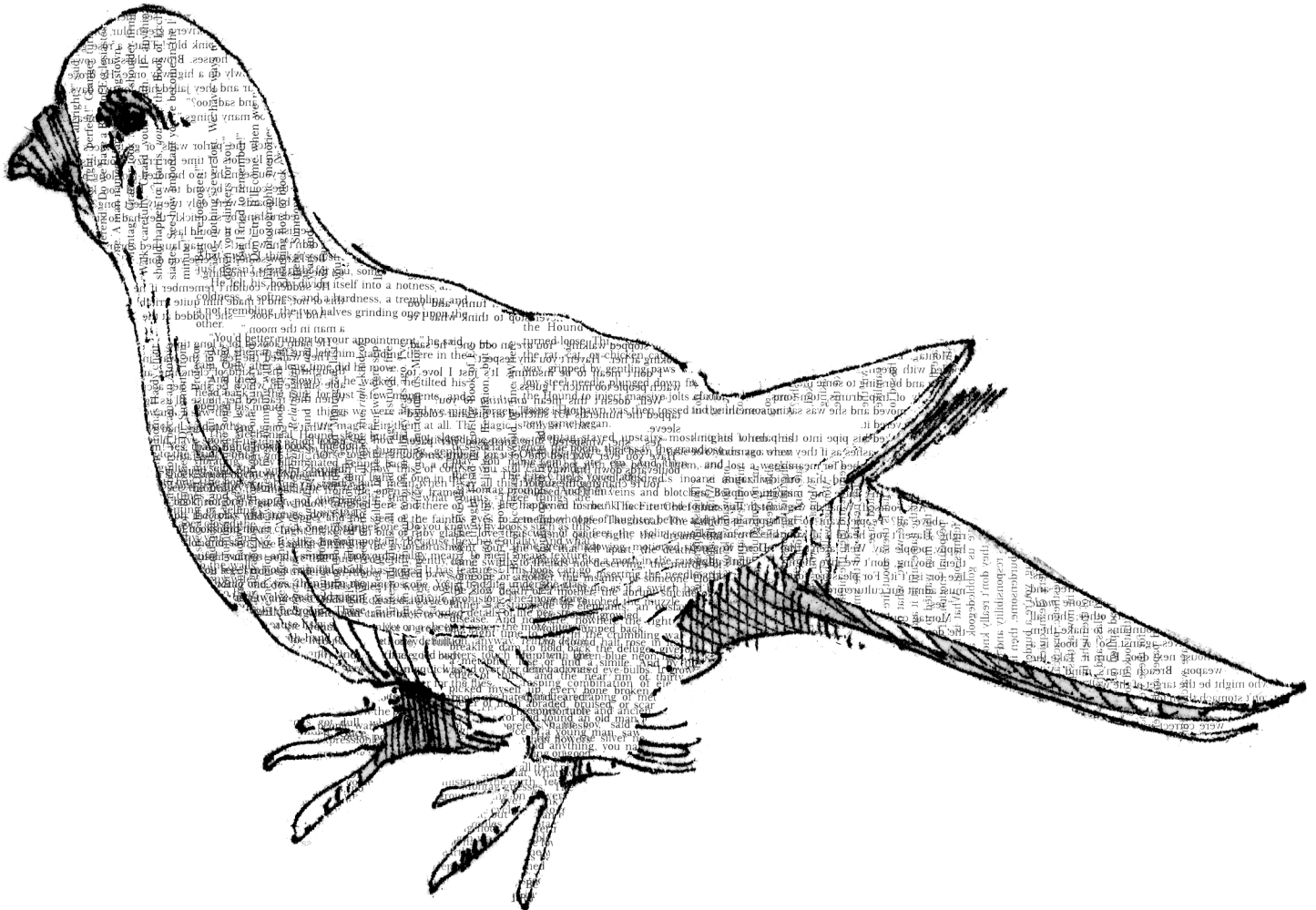

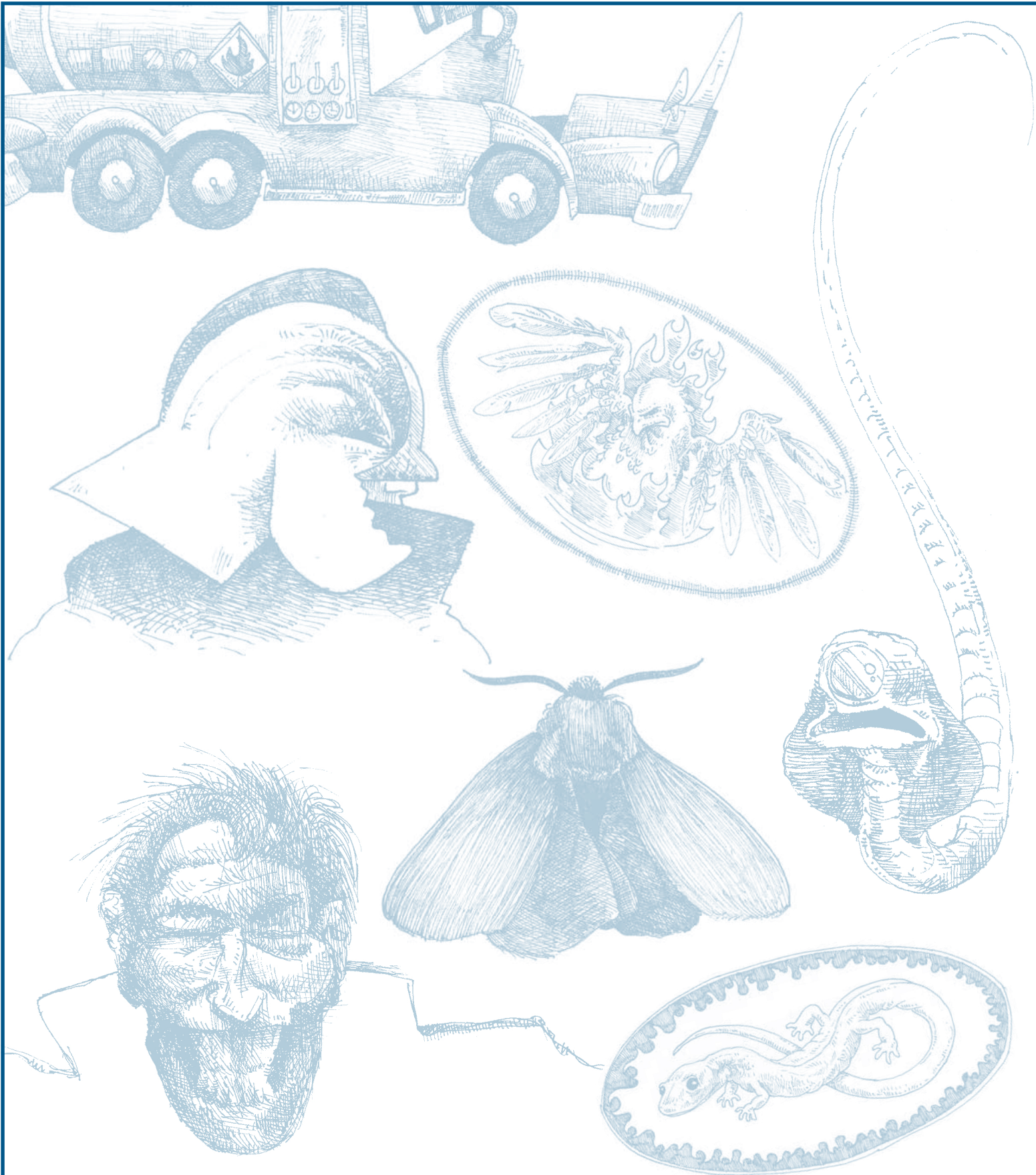

veritas
PRESS

ISBN 978-1-932168-19-8 US\$13.95



9 781932 168198

5 1 3 9 5

